

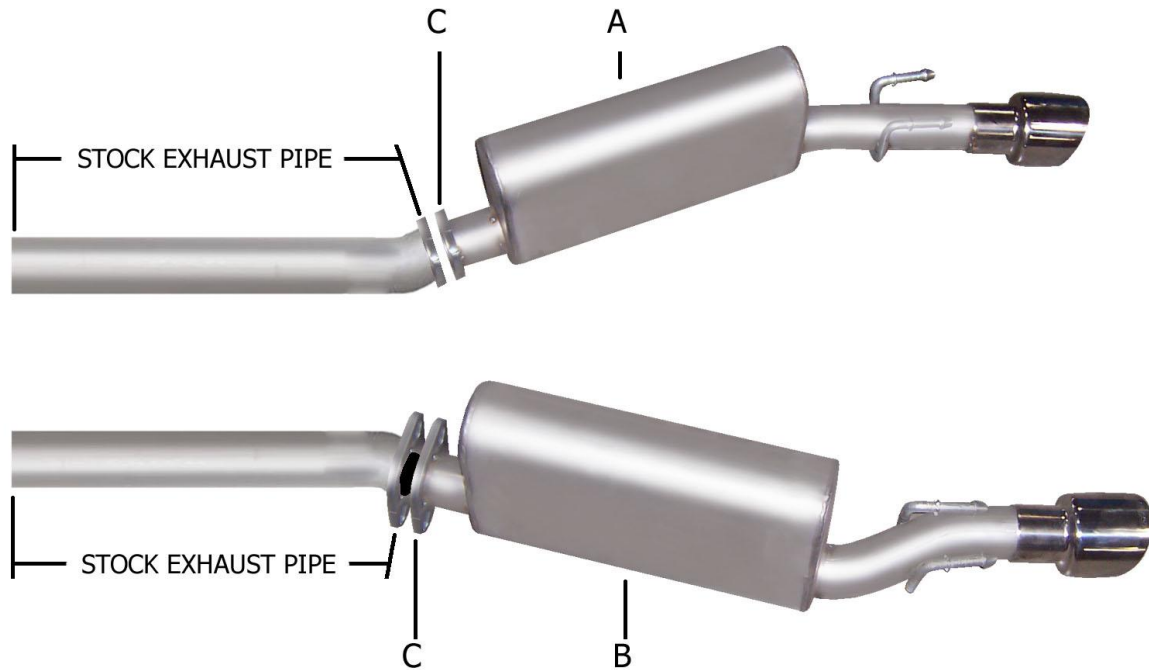

**INSTALLATION INSTRUCTIONS
DUAL STAINLESS REAR MUFFLER REPLACEMENT
PONTIAC GTO 6.0L LS2
PART #618000**



ITEM	PART #	QUANTITY	DESCRIPTION
A	1050-700789S	1	STAINLESS PASSENGER SIDE MUFFLER ASSEMBLY WITH/ WELDED TIP
B	1051-700790S	1	STAINLESS DRIVER SIDE MUFFLER ASSEMBLY WITH/ WELDED TIP
C	BO-1026	1	BOLT KIT FOR FLANGE

Thank you for purchasing our Gibson exhaust system for your vehicle. If you need further assistance, please do not hesitate to call our technical dept at (800) 528-3044 Monday through Friday, 8:00 am to 5:00 pm.

INSTALLATION INSTRUCTIONS #618000

CAREFULLY READ INSTRUCTIONS BEFORE STARTING INSTALLATION.

When installing this exhaust system make sure to use proper safety precautions. Use jack stands when working under the vehicle, set parking brake, block tires and use safety glasses and gloves. Allow exhaust to cool before attempting installation. Severe injury or burns could occur if safety measures are not taken.

SUGGESTED TOOLS: 1/2", 9/16" 15mm wrenches & sockets, WD-40, hacksaw, jack stands.

Disconnect the negative battery cable before removal of OEM exhaust. This will allow the computer to reset and recognize the new exhaust. Lay out the exhaust on the floor so it looks like the drawing and compare parts with manual.



1. To remove the stock exhaust, remove the clips from the rubber grommets then remove rubber grommets. DO NOT DAMAGE OR THROW AWAY THEY WILL BE RE-USED.



4. Install driver side muffler assembly #A onto stock flange using bolt kit #C. Use a jack stand to support the muffler to insert welded hangers into rubber grommets. Insert clips onto hangers.



2. Unbolt factory muffler from flange located in front of muffler and remove. Repeat for other side.



3. Install passenger side muffler assembly #A onto stock flange using bolt kit #C. Use a jack stand to support the muffler to insert welded hangers into rubber grommets. Insert clips onto hangers.



5. When you have everything in place, firmly tighten all bolts and clamps down securely. Use stainless steel cleaner and a Scotch Brite pad weekly to prevent tip from discoloration.



GIBSON EXHAUST systems are designed on a factory stock vehicle. Any aftermarket products installed could increase the sound levels of this Exhaust.

Make sure there is a 1" clearance from ALL rubber brake lines, shock boots, fuel lines, tires, etc to prevent heat related damage or fire.