



INSTRUCTION MANUAL

CAT-BACK STAINLESS SINGLE EXHAUST

CHEVY TRUCK 5.7L HD, 7.4L 2/4WD

EXTENDED CAB, LONG BED

PART # 615510

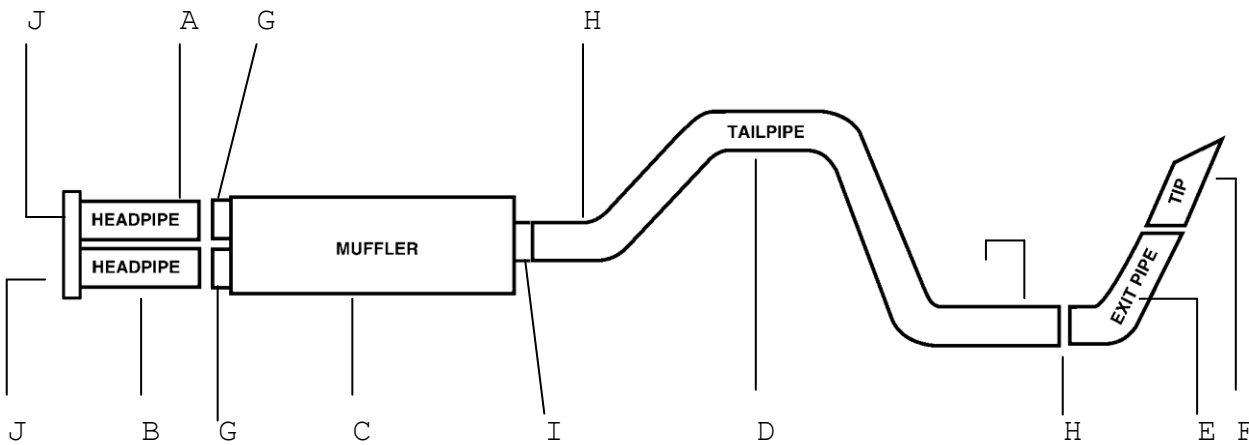

ITEM	PART #	QUANTITY	DESCRIPTION
A	166-600001S	1	2-1/2" STAINLESS PASSENGER SIDE HEADPIPE
B	167-600002S	1	2-1/2" STAINLESS DRIVER SIDE HEADPIPE
C	758250S	1	STAINLESS SUPERFLOW MUFFLER
D	165-500628S	1	3" STAINLESS OVERAXLE TAILPIPE
E	154-50032RS-2	1	3" STAINLESS TURNOUT PIPE
F	500360	1	3-1/2" STAINLESS TIP
G	5757	2	2-1/2" CLAMP
H	OHD300	2	3" CLAMP
I	500569	1	REAR MUFFLER HANGER
J	5758	2	2-3/4" CLAMP

Thank you for purchasing our GIBSON EXHAUST SYSTEM for your vehicle. If you need further assistance, please do not hesitate to call our Technical Department at (800) 528-3044, Monday through Friday, 8:00 am to 5:00 pm.

EXHAUST INSTALLATION

WHEN INSTALLING THIS EXHAUST SYSTEM, MAKE SURE TO USE PROPER SAFETY PRECAUTIONS. USE JACK STANDS WHEN UNDER THE TRUCK, SET PARKING BRAKE, BLOCK TIRES, AND USE SAFETY GLASSES AND GLOVES. **DO NOT WORK ON HOT PIPES!**

SUGGESTED TOOLS:

9/16" SOCKET, 7/8" WRENCH, 1/2" WRENCH, 1/2" SOCKET, HACKSAW, JACK STAND



LAY OUT THE GIBSON EXHAUST SO IT LOOKS LIKE THE DRAWING AND COMPARE THE PART NUMBERS. FOR AN EASIER REMOVAL OF THE FACTORY EXHAUST CUT THE TAILPIPE BEHIND THE MUFFLER. THEN CUT 18" IN FRONT OF THE FACTORY MUFFLER AND REMOVE. **LEAVE ALL FACTORY RUBBER GROMMETS IN PLACE.**

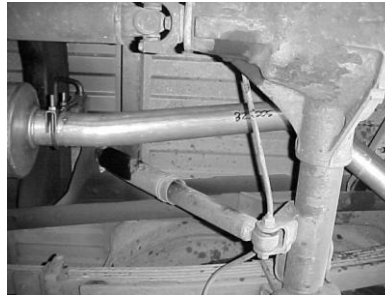

SLIP OVER AXLE PIPE #D INTO THE OUTLET OF THE MUFFLER NO MORE THEN 2" AND NO LESS THEN 1". SLIP WELDED HANGER INTO THE FACTORY RUBBER GROMMET AND ATTACH WITH CLAMP #H.



INSTALL HEADPIPE'S A & B ONTO THE FACTORY HEADPIPE'S. SLIP HEADPIPE #B'S INSERT WELDED HANGER INTO THE RUBBER GROMMET. ROTATE THE HEADPIPES UNTIL THEY ARE POSITIONED DIRECTLY NEXT TO EACH OTHER. USE CLAMPS #J TO ATTACH THE HEADPIPE'S TO THE FACTORY PIPE. DO NOT TIGHTEN



INSTALL EXIT PIPE #E. USE CLAMP #H TO CLAMP IT DOWN. DO NOT TIGHTEN. ROTATE THE PIPE'S UNTIL YOU HAVE A MINIMUM OF A 1" CLEARANCE ON ALL PIPE'S AND HANGERS FROM ALL RUBBER BRAKE LINE'S, TIRES, SHOCKS, FUEL LINES, ETC. THEN TIGHTEN ALL CLAMPS AND HANGERS.



INSTALL MUFFLER #C. THE OUTLET OF THE MUFFLER WILL BE POSITIONED AT THE TOP OF THE MUFFLER. USE A JACK STAND TO SUPPORT THE MUFFLER. INSTALL REAR MUFFLER HANGER #I WITH THE VERTICAL ROD FACING TOWARDS THE PASSENGER SIDE. DO NOT TIGHTEN



NOW INSTALL YOUR STAINLESS STEEL TIP TO YOUR DESIRED LOOK. USE ANY ALUMINUM OR STAINLESS STEEL CLEANER TO POLISH YOUR TIP.

"MAKE SURE HAVE A MINIMUM OF A 1" CLEARANCE ON ALL PIPES FROM ALL RUBBER BRAKE LINES, TIRES, SHOCKS, FUEL LINES, ETC."