

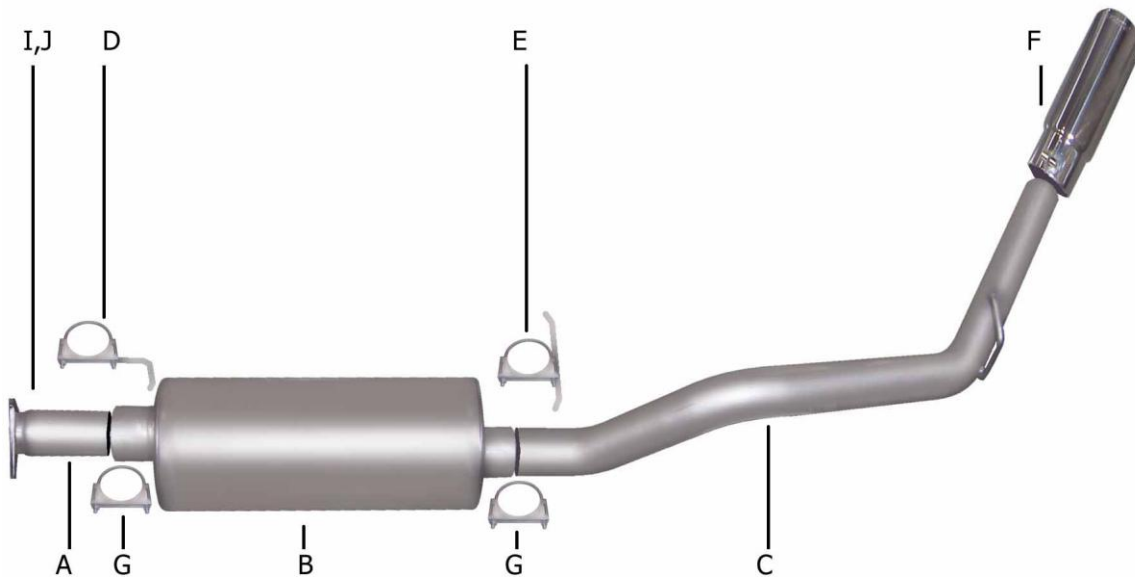

INSTRUCTION MANUAL
CAT-BACK SINGLE EXHAUST
ASTRO & SAFARI VAN 4.3L 2/4WD
PART # 315500



ITEM	PART #	QUANTITY	DESCRIPTION
A	60003	1	HEADPIPE WITH FLANGE #GP-101
B	788824	1	SUPERFLOW MUFFLER
C	500459-H	1	3" OVERAXLE TAILPIPE
D	4102	1	FRONT MUFFLER HANGER
E	4103	1	REAR MUFFLER HANGER
F	500360	1	3-1/2" STAINLESS TIP
G	OHD300	2	3" CLAMP
H	BO-1011	1	BOLT KIT FOR HEADPIPE
I	9684	1	HEADPIPE GASKET

Thank you for purchasing our GIBSON EXHAUST SYSTEM for your vehicle. If you need further assistance, please do not hesitate to call our Technical Department at 1-800-528-3044, Monday through Friday, 8:00 AM to 5:00 PM.

EXHAUST INSTALLATION

PART #315500

WHEN INSTALLING THIS EXHAUST SYSTEM, MAKE SURE TO USE PROPER SAFETY PRECAUTIONS. USE JACK STANDS WHEN UNDER TRUCK, SET PARKING BRAKE, BLOCK TIRES, AND USE SAFETY GLASSES AND GLOVES. DO NOT WORK WITH HOT PIPES!

SUGGESTED TOOL

15MM & 9/16" SOCKET, 1/2" WRENCH & SOCKET, JACK STAND, WD-40, HACKSAW



LAY OUT THE GIBSON EXHAUST ON THE FLOOR AND COMPARE PART #'S TO THE DRAWING. UNBOLT STOCK EXHAUST FROM BEHIND CATALYTIC CONVERTER. USE JACK STANDS TO SUPPORT CONVERTER SO IT WILL NOT DROP.



SLIDE MUFFLER ONTO THE FRONT HEADPIPE WITH THE INLET TOWARDS THE CONVERTER (MUFFLER INLET IS LOOKING INTO LOUVERS). USE THE JACK STAND TO SUPPORT THE MUFFLER AND CLAMP USING #G. DO NOT TIGHTEN. MUFFLER OUTLET SHOULD BE POSITIONED AT 9 O'CLOCK



BOLT FRONT HEADPIPE #A ONTO STOCK FLANGE USING SUPPLIED BOLT KIT #H AND GASKET #I. INSERT WELDED HANGER INTO RUBBER GROMMET.



INSTALL THE OVER AXLE TAIL PIPE #C AND ATTACH WITH CLAMP #G AND CONNECT WITH HANGER #E. INSERT WELDED HANGER INTO RUBBER GROMMET.



INSERT HANGERS #D AND #E INTO RUBBER GROMMET.



INSTALL STAINLESS STEEL TIP, CLAMP DOWN. NOW TIGHTEN ALL BOLTS AND CLAMPS. TO CLEAN TIP US SCOTCH BRITE AND ANY STAINLESS OR ALUMINIUM CLEANER.

SPECIAL NOTES:

MAKE SURE YOU HAVE A 1" CLEARANCE ON ALL PARTS FROM ALL RUBBER BRAKE & FUEL LINES, SHOCK BOOTS, TIRES, ETC.