

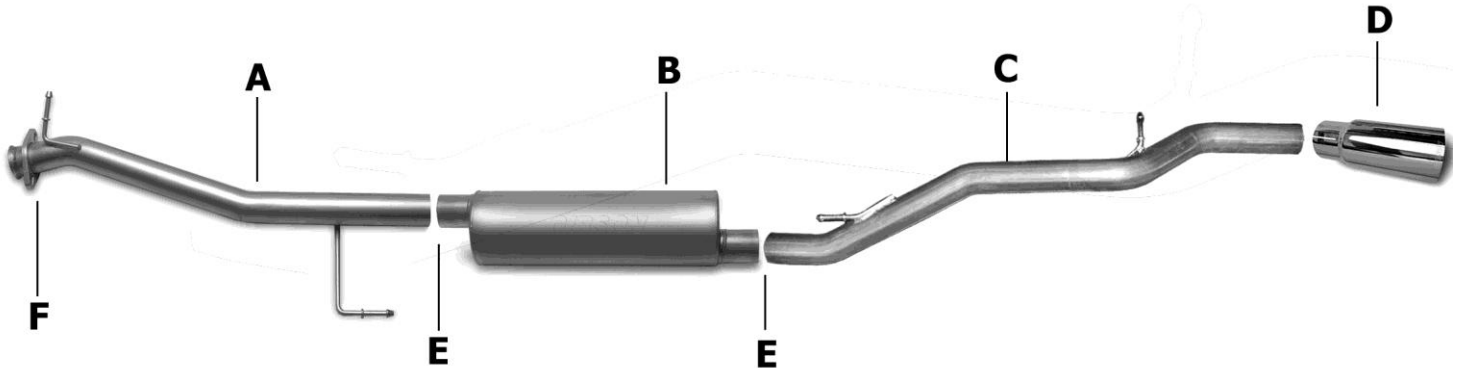

# INSTALLATION INSTRUCTIONS

## CAT-BACK SINGLE REAR EXHAUST

Honda Element 2.4L 2wd 4dr & SC Model  
PART #314001



ITEM	PART #	QTY	DESCRIPTION
A	700862	1	2 1/4" Headpipe w/ GP-120 Flange + welded hanger
B	788500-8	1	Superflow Muffler
C	701048	1	2 1/4" Tailpipe w/ welded hanger
D	500395	1	3 1/2" Stainless tip
E	5756	2	2 1/4" Clamp Kit
F	BO-1056	1	Bolt Kit for Flange

\*\* Will fit with factory SC Body Kit. \*\*

Thank you for purchasing our Gibson exhaust system for your vehicle.  
If you need further assistance, please do not hesitate to call our technical dept at (800) 528-3044  
Monday through Friday, 8:00 am to 5:00 pm.

# INSTALLATION INSTRUCTIONS #314001

## CAREFULLY READ INSTRUCTIONS BEFORE STARTING INSTALLATION

When installing this exhaust system make sure to use proper safety precautions. Use jack stands when working under the vehicle, set parking brake, block tires and use safety glasses and gloves. Allow exhaust to cool before attempting installation. Severe injury or burns could occur if safety measures are not taken.

**SUGGESTED TOOLS:** 1/2", 9/16" 15mm wrenches & sockets, WD-40, hacksaw, jack stands.

**1.** Disconnect the negative battery cable before removal of OEM exhaust. This will allow the computer to reset and recognize the new exhaust. Lay out the exhaust on the floor so it looks like the drawing and compare parts with manual.



**2.** To remove the stock exhaust, unbolt the 2 bolt flange located in front of the new muffler. Disengage the welded hangers using WD-40 from the OEM rubber grommets. Do not damage or remove the rubber grommets as you will reuse them to mount your new system. Now, cut off tailpipe and remove exhaust.



**4.** Install muffler #B onto headpipe 1 1/2"-2" with the louvers facing towards the converter. Use a jack stand to support the muffler. Use clamp #E to secure the muffler to the headpipe. Do not tighten. Muffler inlet is looking into the louvers. Outlet of muffler will be at approximately 2 o'clock.



**3.** Bolt head pipe #A onto your existing stock front pipe and attach with bolt kit #F. Use a jack stand to support the converter. Insert welded hangers into rubber grommets.



**5.** Install the overaxle tailpipe #C to the muffler 1 1/2"-2". Use clamp #E to secure tailpipe to muffler. Insert welded hanger into rubber grommet.



**11.** Install stainless steel tip. Clamp down. When you have everything in place, firmly tighten all bolts and clamps down securely. Use stainless steel cleaner and a Scotch Brite pad weekly to prevent tip from discoloration. Inspect all fasteners after 25-50 miles of operation and re-tighten as necessary.



GIBSON EXHAUST systems are designed on a factory stock vehicle. Any aftermarket products installed could increase the sound levels of this exhaust. **Make sure there is a 1" clearance from ALL rubber brake lines, shock boots, fuel lines, tires, etc to prevent heat related damage or fire.**