



# INSTRUCTION MANUAL

## CAT-BACK SINGLE EXHAUST

### HUMMER H2/SUT 6.0L, 4DR AWD

**PART # 312500**

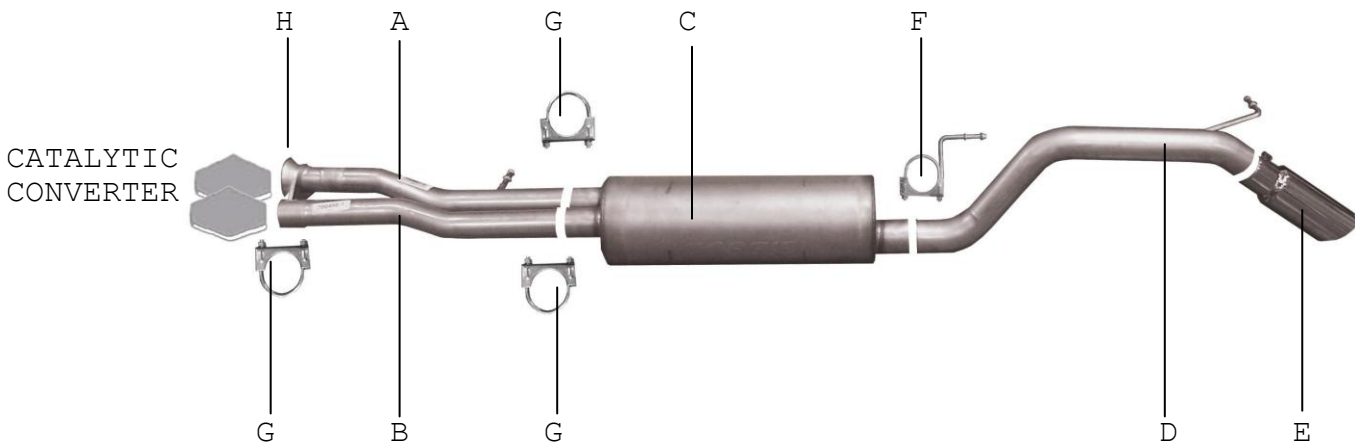

ITEM	PART #	QUANTITY	DESCRIPTION
A	700467-1	1	2-1/2" PASS. SIDE HEADPIPE W/HANGER
B	700468-1	1	2-1/2" DRIVER SIDE HEADPIPE
C	758250	1	SUPERFLOW MUFFLER
D	700469	1	3" OVERAXLE TAILPIPE W/HANGER
E	500379	1	4" STAINLESS TIP
F	4209	1	3" REAR MUFFLER HANGER
G	5757	3	2-1/2" CLAMP
H	BO-1028	1	BOLT KIT FOR HEADPIPE

Thank you for purchasing our GIBSON EXHAUST SYSTEM for your vehicle. If you need any further assistance, please do not hesitate to call our Technical Department at 1-800-528-3044 Monday through Friday, 8:00 AM to 5:00 PM

# EXHAUST INSTALLATION #312500

When installing this exhaust system make sure to use proper safety precautions. Use jack stands when under the truck, set parking brake, block tires and use safety glasses and gloves.

**DO NOT WORK WITH HOT PIPES!**

## SUGGESTED TOOLS:

1/2" , 9/16", 15mm Socket & Wrench, WD-40, Jack Stand, Hacksaw

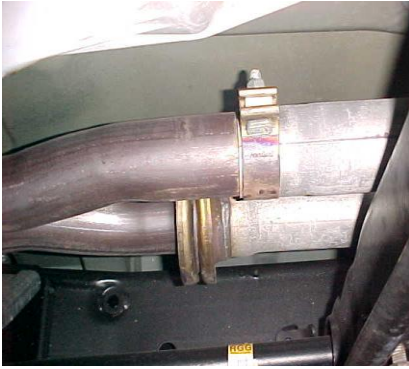

Lay out the exhaust on the floor so it looks like the drawing and compare parts with manual. To remove the stock exhaust remove it from the stock flange & slip joint located in front of the muffler, then cut off your tailpipe just behind the muffler. Use WD-40 to aid in removal of hangers from grommets leave grommet on vehicle.



Install the over axle tailpipe # D into the muffler 1-1/2" to 2". Insert welded hanger into rubber grommet.

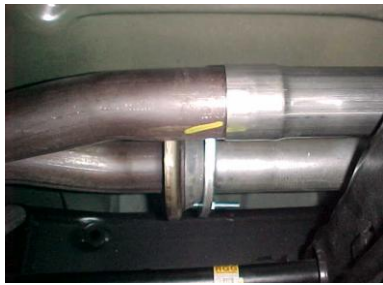

Install passenger side head pipe # A onto stock flange using hardware provided, do not tighten. Insert welded hanger into rubber grommet. Next, install driver side headpipe # B onto stock pipe, use clamp # G to secure together, do not tighten.



Install rear muffler hanger #F onto outlet of muffler and clamp down to tailpipe. Insert hanger into rubber grommet. Do not tighten.



Install muffler #C onto head pipes B 1-1/2" to 2" with the louvers facing towards the converter. Use a jack stand to support the muffler. Use clamps #G to secure the muffler to the head pipes. Do not tighten. Outlet of muffler should be at 6 o'clock.



Install stainless steel tip # E. Clamp down. When you have everything in place, firmly tighten all bolts and clamp down securely. To clean stainless steel tip use any stainless steel cleaner and Scotch Brite pad.

**MAKE SURE YOU HAVE A 1" CLEARANCE ON ALL RUBBER BRAKE LINES, SHOCK BOOTS, TIRES, FUEL LINES, ETC.. TIGHTEN ALL CLAMPS TO 100 TO 150 FT. LBS.**