

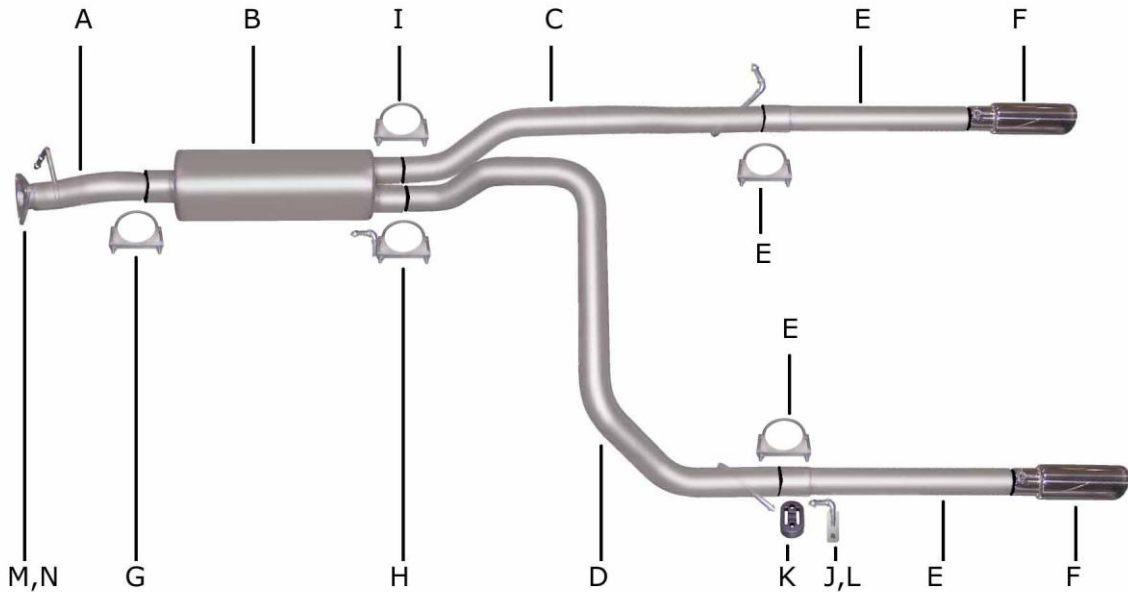

**INSTRUCTION MANUAL**  
**CAT-BACK STAINLESS**  
**DUAL SPLIT REAR STAINLESS EXHAUST**  
**Chevrolet Astro Van 4.3L V6 2/4 wd**  
**PART # 65608**



ITEM	PART #	QTY.	DESCRIPTION
A	948-700724S	1	3.00" Stainless Headpipe w/ welded hanger w/ GP-101 Flange
B	758219S	1	Stainless SuperFlow Muffler
C	949-700725S	1	2.50" S.S Passenger Side over-axle tailpipe w/ welded hanger
D	950-700726S	1	2.50" Stainless Driver Side over-axle w/ welded hanger
E	546-700346S	2	2.50" Stainless Exit pipe
F	500374	2	3.50" Stainless tip
G	OHD300	1	3.00" Clamp
H	4253	1	Rear muffler hanger clamp
I	5757	4	2.50" Clamp(s)
J	4254	1	Rear Tailpipe hanger
K	4240	1	Rubber grommet
L	BO-1047	1	Bolt kit for rear tailpipe hanger
M	BO-1048	1	Bolt kit for headpipe flange
N	9684	1	Flange Gasket

**THANK YOU FOR PURCHASING OUR GIBSON EXHAUST SYSTEM FOR YOUR VEHICLE. IF YOU NEED FURTHER ASSISTANCE, PLEASE DO NOT HESITATE TO CALL OUR TECHNICAL DEPT. AT (800) 528-3044, MONDAY THROUGH FRIDAY, 8:00 AM TO 5:00 PM.**

# EXHAUST INSTALLATION #665608

WHEN INSTALLING THIS EXHAUST SYSTEM, MAKE SURE TO USE PROPER SAFETY PRECAUTIONS. USE JACK STANDS WHEN UNDER TRUCK, SET PARKING BRAKE, BLOCK TIRES, AND USE SAFETY GLASSES AND GLOVES.  
**DO NOT WORK WITH HOT PIPES!**

## SUGGESTED TOOLS:

9/16" SOCKET, 15MM SOCKET, 1/2" WRENCH, 1/2" SOCKET, JACK STAND, HACKSAW, WD-40

**LAY OUT THE GIBSON EXHAUST SO IT LOOKS LIKE THE DRAWING AND COMPARE THE PART NUMBERS.**



Lay out the exhaust on the floor so it looks like the drawing and compare the parts with the manual. To remove the stock exhaust, un-bolt it from the 3-bolt flange located in front of the muffler. **NOTE: For an easy removal of the exhaust, cut the tailpipe off behind the muffler.** Leave all rubber grommets in place. Use WD-40 to aid in removal.



Install the Passenger side over-axle tailpipe # C to the muffler, 1-1/2" to 2". Insert welded hanger into rubber grommet. Use clamp # I secure the tailpipe to the muffler.

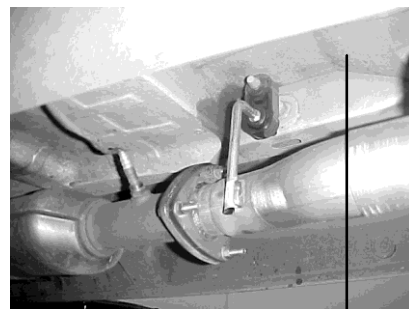

Install your head-pipe # A onto your existing stock flange, use your supplied hardware # N and gasket in the kit. Use a jack stand to support the converter. Insert the welded hanger into the rubber grommet.



Install tailpipe hanger # J on the frame, then measure 9" from the rear; you will see a 1" round hole use this to mount your hanger. Use the bolt kit and rubber grommet provided in your kit, # K & L

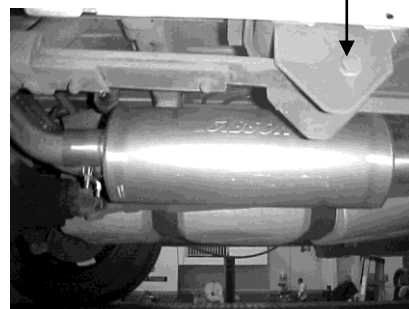

Install muffler #B onto head-pipe #A 1-1/2" to 2" with the louvers in the muffler facing towards the converter. Use a jack stand to support the muffler. Use Clamp #G to secure the muffler to the head-pipe. **Do Not Tighten at this Time!**



Install the Driver side over-axle tailpipe #D into the muffler 1-1/2" to 2". Then insert the welded hanger into the rubber grommet. Use clamp #H to secure it to the muffler. **Do Not Tighten at this Time!**



Install rear muffler hanger #H. Onto driver side outlet of the muffler, insert hanger into rubber grommet.



Next, install the exit pipes #E. Use clamps #I to secure them.



Install your Stainless Steel tips and clamp down. When you have everything in place \*, firmly tighten all your hardware and clamps securely down. To clean your stainless steel tips, use a stainless cleaner and polish.

**\*MAKE SURE YOU HAVE A 1" CLEARANCE ON ALL BRAKE LINES, FUEL LINES, SHOCKS, TIRES, ETC...**