



PERFORMANCE EXHAUST SYSTEMS

# INSTRUCTION MANUAL CAT-BACK SINGLE EXHAUST

TOYOTA TACOMA 4.0L 2/4WD  
TOYOTA TACOMA PRE-RUNNER 4.0L 2WD  
ACCESS & DOUBLE CAB, SHORT BED

## PART # 18802

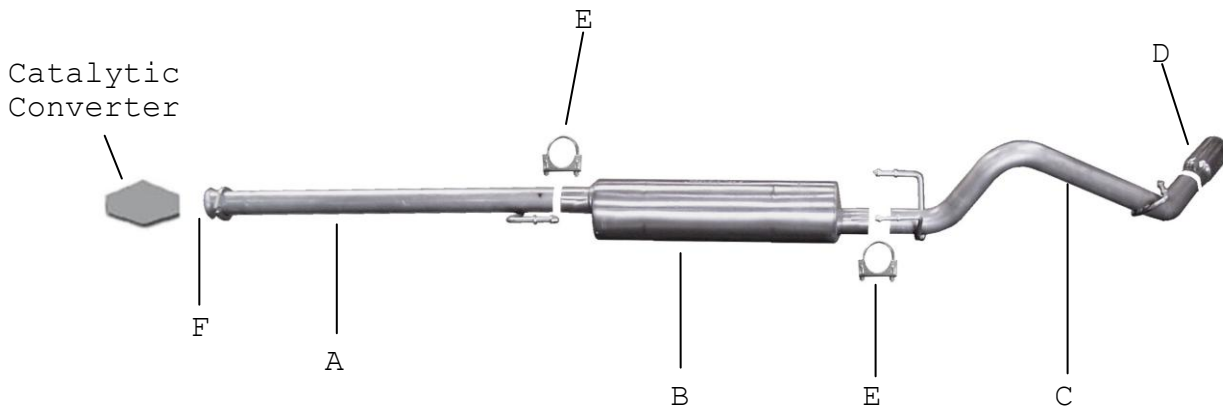

ITEM	PART #	QTY	DESCRIPTION
A	700663	1	2-1/2" HEADPIPE W/ FLANGE #GP-532
B	788500	1	SUPERFLOW MUFFLER
C	700664	1	2 1/2" TAILPIPE W/ HANGERS
D	500374	1	3" STAINLESS TIP
E	5757	2	2 1/2" CLAMP
F	BO-1036	1	BOLT KIT FOR HEADPIPE FLANGE

**WILL NOT FIT ON X-RUNNER**

Thank you for purchasing our GIBSON EXHAUST SYSTEM for your vehicle.  
If you need further assistance, please do not hesitate to call our  
Technical Department at (800) 528-3044, Monday through Friday, 8:00 am  
to 5:00 PM.

# INSTALLATION INSTRUCTIONS

## PART #18802

WHEN INSTALLING THIS EXHAUST SYSTEM, MAKE SURE TO USE PROPER SAFETY PRECAUTIONS. USE JACK STANDS WHEN UNDER THE TRUCK, BLOCK TIRES AND USE SAFETY GLASSES AND GLOVES. DO NOT WORK WITH HOT PIPES!

### SUGGESTED TOOLS

1/2", 9/16", 15MM, 17MM, SOCKET & WRENCH, WD-40, JACK STAND, HACKSAW

LAY OUT THE EXHAUST ON THE FLOOR SO IT LOOKS LIKE THE DRAWING AND COMPARE PARTS WITH MANUAL. TO REMOVE THE STOCK EXHAUST REMOVE IT FROM THE 2-BOLT FLANGE LOCATED IN THE FRONT OF THE MUFFLER. LEAVE ALL RUBBER GROMMETS IN PLACE. USE WD-40 TO AID IN REMOVAL OF EXHAUST AND HANGERS.



INSTALL THE OVERAXLE TAILPIPE #C INTO THE MUFFLER 1-1/2" TO 2". INSERT WELDED HANGERS INTO RUBBER GROMMET. SECURE TO THE MUFFLER USING CLAMP #E. DO NOT TIGHTEN.

INSTALL HEAD PIPE #A ON TO YOUR EXISTING STOCK 2-BOLT FLANGE AND SECURE WITH BOLT KIT #F. INSERT WELDED HANGER INTO RUBBER GROMMET. DO NOT TIGHTEN



INSTALL MUFFLER #B ONTO HEAD PIPE 1-1/2" TO 2" WITH THE LOUVERS FACING TOWARDS THE CONVERTER. THE MUFFLER OUTLET SHOULD BE POSITIONED AT 12:00. USE A JACK STAND TO SUPPORT THE MUFFLER. USE CLAMP #E TO SECURE THE MUFFLER TO THE HEAD PIPE. DO NOT TIGHTEN. MUFFLER INLET IS LOOKING INTO THE LOUVERS.



NEXT INSTALL YOUR STAINLESS STEEL TIP TO YOUR DESIRED LOOK. USE ANY ALUMINUM OR STAINLESS STEEL CLEANER TO POLISH YOUR TIP. MAKE SURE YOU HAVE A MINIMUM OF A 1" CLEARANCE ON ALL PIPES FROM ALL RUBBER BRAKE LINES, TIRES, SHOCKS, FUEL LINES, ETC. THEN TIGHTEN ALL CLAMPS AND HANGERS

**"MAKE SURE YOU HAVE A MINIMUM OF A 1" CLEARANCE ON ALL PIPES FROM ALL RUBBER BRAKE LINES, TIRES, SHOCKS, SPARE TIRE, FUEL LINES, ETC."**