

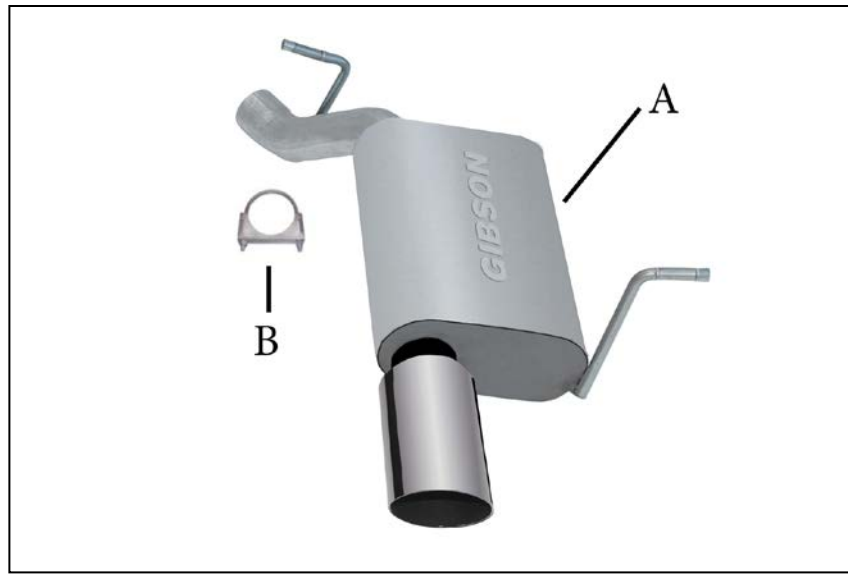

# INSTALLATION INSTRUCTIONS

Axle Back Aluminized Exhaust  
2011-2013 Jeep Grand Cherokee 3.6L 2/4WD

**PART #17408**



ITEM	PART #	QTY	DESCRIPTION
A	999700769	1	2.50" Passenger Side Muffler Assembly
B	5757	1	2.50" Exhaust Clamp

Thank you for purchasing our Gibson Exhaust system for your vehicle.  
If you need further assistance, please do not hesitate to call our technical dept at (800) 528-3044  
Monday through Friday, 8:00 am to 5:00 pm. 5/13

# EXHAUST INSTALLATION

## PART# 17408

WHEN INSTALLING THIS EXHAUST SYSTEM MAKE SURE TO USE ALL THE PROPER SAFETY PRECAUTIONS. USE JACK STANDS WHEN UNDER TRUCK, SET PARKING BRAKE, BLOCK TIRES AND USE SAFETY GLASSES.

**DO NOT WORK WITH HOT PIPES!!!**

1. Disconnect the negative battery cable before removal of the OEM Exhaust. This will allow the computer to reset and recognize the new exhaust. Lay out the exhaust on the floor so it looks like the drawing and compare parts with manual. Be sure all part numbers and your vehicle model match the instruction manual before removing your factory exhaust.



2. To remove the factory exhaust measure from the rear bend 3" forward. Please reference picture for location. Mark and cut with a hack saw or cut off wheel. Leave the factory rubber grommets in place they will be re used.



3. Install the driver side muffler assembly onto the factory pipe. and into the factory rubber grommets. Do not tighten.



4. Be sure hanger is correctly installed into the rubber grommet for complete support.



5. With the muffler assembly in place align the tip so it is centered in the exhaust outlet. You may need to use something like a rag to hold the tips in place while the clamp is being tightened.



6. With the Exhaust installed and tight clean your Stainless steel tips so that all finger prints have been removed and enjoy your new performance exhaust.

**"MAKE SURE YOU HAVE A 1" CLEARANCE ON ALL PIPES FROM ALL RUBBER BRAKE LINES, SHOCK BOOTS, TIRES, ETC..." TORQUE ALL CLAMPS TO APPROX. 100 TO 150 FT LBS.**